



18

Wartungsdienst - Typ 3

Maintenance Service - Type 3

Service d'entretien - Type 3

Servicio de Mantenimiento - Tipo 3

585280

Made in Germany

**Maintenance Service
for Volkswagen 1500**



18/1 – Cars now-a-days have acquired a noticeable degree of technical perfection and reliability. The best vehicle, however, still requires regular maintenance and care if its good basic construction and properties are to be retained. There is no such thing as a completely maintenance-free vehicle and for various reasons there will not be one for a long time to come. One of the most important reasons is to keep the vehicle road-safe.



km

2500

5000

7500

10000

12500

15000

17



18/2 – The proven 3000 mile maintenance interval is also applicable to the Type 3 – which is the internal designation of the Volkswagen 1500. If we compare the VW 1500's lubrication chart with that of the Type 1 – Volkswagen 1200, we notice that the lubrication service too is only carried out at the same 3000 mile intervals – the further developed front axle of the Type 3 with its ball joints which need little servicing does not require the in-between lubrication.



F-DR 666

18/3 – The construction of the Type 3 is based on the VW 1200. Both vehicles have the same wheelbase and other vehicle measurements do not differ considerably. Existing workshop equipment, in particular the Volkswagen maintenance stands can also be used for Type 3, and the similarity in the maintenance service between Type 3 and the VW 1200 is clearly recognizable. Let us now deal with the sequence of the lubrication and maintenance service as it is carried out on the hoist during the rationalized maintenance service.



18/4 – Before raising the vehicle, check the steering play. Turn the wheels to the straight-ahead position and move the steering wheel at the outer end of the spoke lightly to and fro as shown here. If the steering is correctly adjusted and the tie rods and steering coupling are in perfect condition it should only be possible to turn the steering wheel 1" until resistance is felt in both directions.

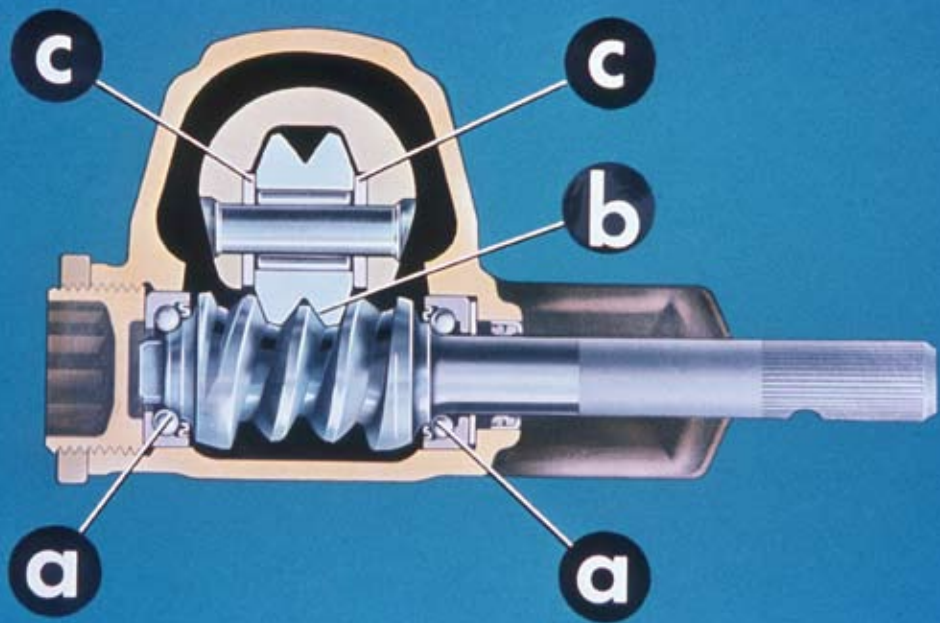

18/5 – If the play is excessive, three points may be at fault:

a – the steering worm

b – the steering roller has play at the steering worm in the center position

c – the steering roller has excessive axial play.

We are only interested in points a and b because during the maintenance service we can only check and adjust these parts. Point c can only be checked when the steering gear is removed and the fault eliminated by replacing the steering roller shaft. Note the following: only after the axial play of the steering worm has at first been checked and corrected is it possible to adjust the steering successfully.

The next two pictures demonstrate this sequence when adjusting the steering gear. During the rationalized maintenance these operations are not carried out in this sequence because the vehicle must be fully raised for the first operation and lowered again for the second one.



18/6 – The presence of steering worm axial play can be ascertained by moving the steering coupling to and fro with the wheels locked.

If there is play, loosen the lock nut and tighten the adjusting screw until no play is detectable. Hold adjusting screw and tighten the lock nut as shown here.

The wrenches shown here are VW 277 and 278 a. When turning the steering worm there should not be any unusually tight positions noticeable. If there are, the adjusting screw is too tight.

If the excessive play at the center position is still present – and to check this the vehicles must be lowered to the ground again – the roller must be adjusted to the steering worm again. The next picture illustrates this.



18/7 – It is best to use the special combination wrench shown here when adjusting the steering roller. We turn the steering wheel 90° to one side, loosen the roller shaft adjusting screw lock nut – the box wrench is shown in position here – and loosen the adjusting screw approximately one turn with a screwdriver. Now we tighten the adjusting screw until the roller contacts the steering worm, we hold the adjusting screw and tighten the lock nut. If we have done this correctly we then check the steering play at 90° to the other side and, if necessary, make corrections in the same manner. It is important to note that the adjustment must always be checked on both sides at a lock of 90° .

If the range of play cannot be adjusted to the prescribed dimension, the steering gear must be removed and the axial play of the steering roller checked.

The vehicle will be road-tested later on to establish whether the newly adjusted steering is sufficiently free. When roadtesting it is important that the steering self-centers nearly to the center position even at speeds of about 9-12 mph.



18/8 – If the vehicle is raised we first of all check the engine and rear axle for leaks during the 300 mile maintenance service. If we were to do this later on, there is the danger that the causes of possible leaks may have been eliminated by the operations already carried out. If small leaks cannot be immediately eliminated by tightening up bolts and clips,

18/9 – an entry should be made in the card "Defects noted during Maintenance" so that the service adviser or foreman can mention this to the customer and in urgent cases arrange for repairs to be carried out immediately after the vehicle has been serviced.

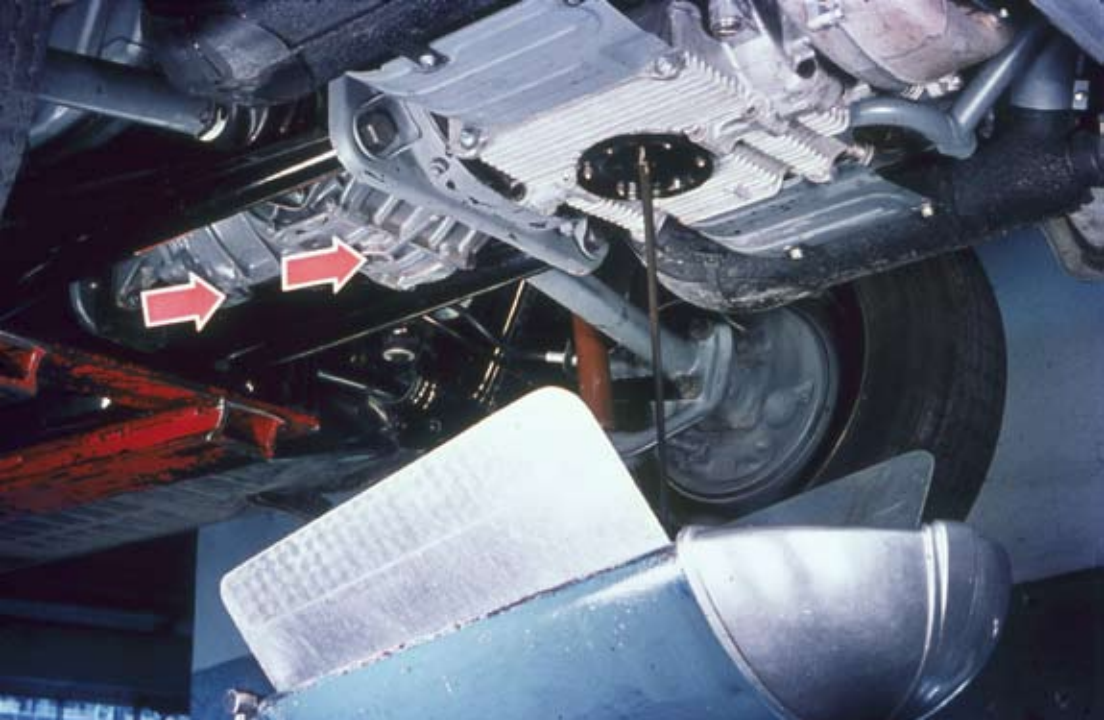

18/10 – After checking for oil leaks we drain the engine oil immediately, and during the 300 mile maintenance service – then every 15,000 miles – the transmission oil. On the one hand impurities will drain off better with the warm thin oil and on the other hand the engine will cool down quicker – a fact which has a major affect on the valve clearance and ignition adjustments which are carried out later on.



18/11 – Of course we do not forget to clean the oil strainer each time and the magnetic oil drain plugs at the prescribed intervals. New strainer gaskets and a new gasket under the engine drain plug are necessary for ensuring freedom from leaks for the next 3,000 miles. Time can be saved if, as shown here, cleaned strainers and drain plugs are kept ready for installation. Every minute saved is of importance during maintenance services.



18/12 – To be on the safe side the oil level in the transmission should be checked after every oil change with the help of the oil dipstick for Type 1 VW 679 local manufacture. The difference between the upper and lower mark is exactly 1.75 Imp. pints and 2.1 US pints.



18/13 – All the 8 grease nipples of the Type 3 are located on the front axle. Whereas grease is inserted into the torsion arm bearings until it emerges at the edge of the lubrication points, the ball joints are lubricated in a different manner.

These joints are sealed with dust seals which can only hold a limited amount of grease. The grease will not emerge as in the case of the nipples. A few shots of grease are sufficient to replenish the grease. Squeeze the seals to see if they are full. In any event stop lubricating when the grease begins to emerge at the small relief holes.

Damaged dust seals must always be replaced. This also applies to the dust seals on the maintenance-free tie rods. Entries should be made immediately in the card "Defects noted during Maintenance" if defects of this kind are noticed.

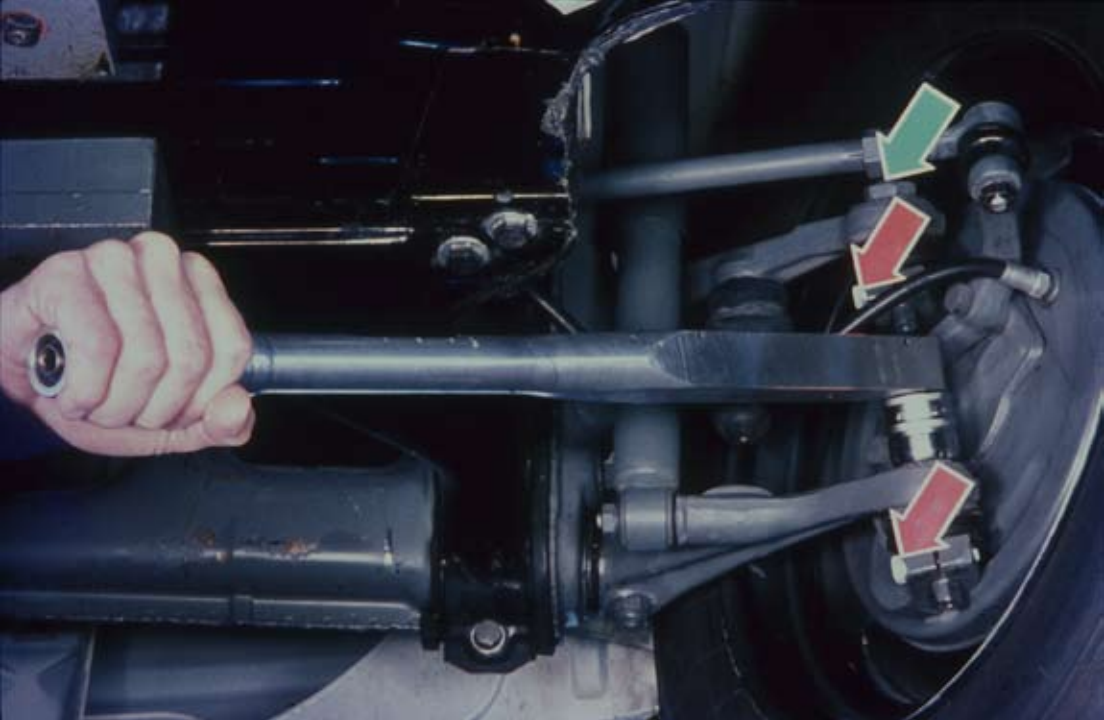

18/14 – The nuts and bolts of the front and rear axles are only tightened during the maintenance service at 300 miles.

Vehicle parts which are secured with lock plates or cotter pins should be checked by hand for movement. Other bolts and nuts should be checked with a wrench for tightness. This includes the parts shown here, ball joint nuts – torque wrench, green arrow – and the clamping bolts shown by the red arrow.

Torque tightness for retaining nuts 80 ft. lbs., for clamping bolts 25 ft. lbs.



18/15 – In the Type 3 the brake shoes are also adjusted by turning the adjusting nuts with a screwdriver. The two wheel cylinders of the front twin leading shoe brakes are offset by 180° as in the VW Commercial. After adjustment the brake pedal should be depressed heavily a few times so as to avoid any danger arising should the brakes shoes not have centered properly.

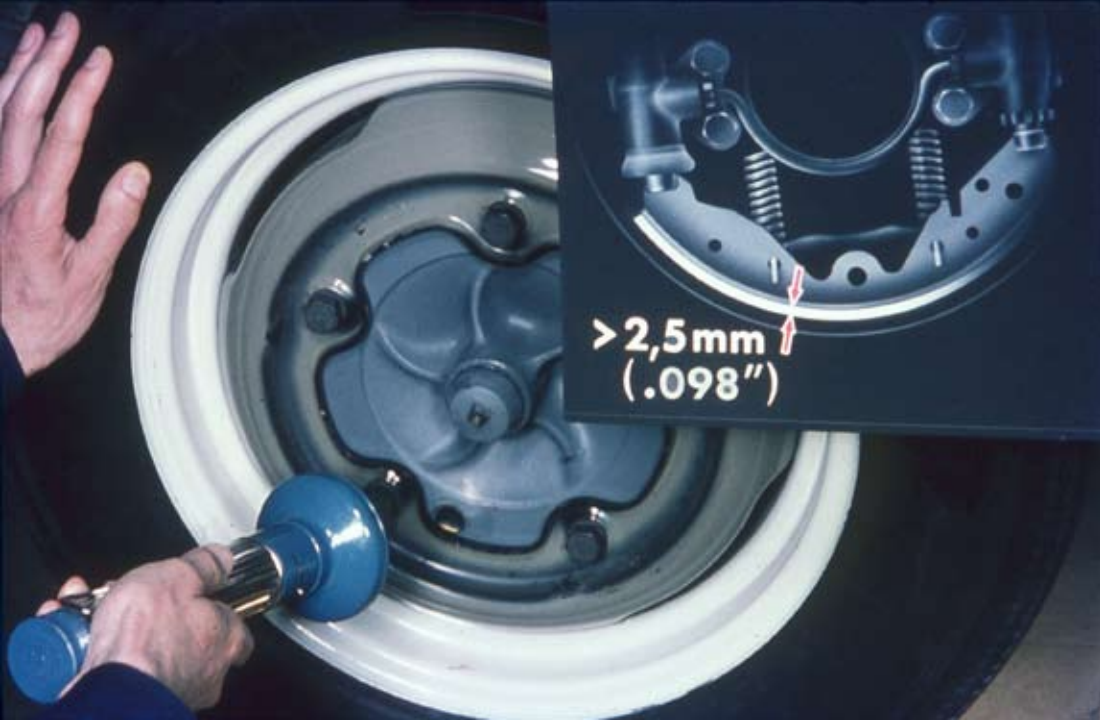

> 2,5mm
(.098")

18/16 – Regular checking of the brake linings is an important contribution to the road safety of a vehicle. As in the case of Type 1, we check the lining thickness by shining a light through the inspection hole in the brake drums. The wear limit is .10" also.



18/17 – A damaged brake line or a worn brake hose, for example, impair the safety of the hydraulic brakes and endanger the lives of the vehicle occupants and other road users. When carrying out a visual check we should be very strict and also carry out this operation very carefully during maintenance services.

Here you see how a twisted and thus incorrectly installed brake hose is nearly caught between rim and frame when the wheels are locked. Under certain driving conditions it might begin to rub. (To illustrate the twist of the hose we have painted the edge of the hose white.)

Take note also of the hoses when making the visual check and bear in mind that contrary to Type 1 the front brake hoses of Type 3 have to be installed without twist and must sag.



18/18 – Do not forget to check the brake line running inside the vehicle: particularly in older vehicles corrosion may set in if the line has been exposed to dampness for a long while.

18/19 – This picture shows all the connection points between frame, sub-frame and body which have to be checked for tightness at the 300 mile maintenance service. If the rubber weatherstrip between frame and body is to remain supple and not be squashed by being over-tightened, the body bolts must be tightened with a torque wrench only.

The bolts marked with red rings – a total of 30 – are accessible from underneath. The 10 bolts illustrated by yellow rings are situated inside the vehicle. 8 are on the rear cross member (under the rear seat) and 2 in the rear luggage compartment.



18/20 -- The water drain flaps are kept closed by vacuum whilst driving and prevent the fan from drawing in air from secondary sources. These flaps act as valves to a certain extent and must have sufficient free movement and seal properly. They are, however, not subject to much wear and are located in a protected position.

In general all we have to do is to keep the contact surfaces and the seal clean.



°C °F

SAE 30

0 -32

SAE 10W

-25 -13

SAE 5W

18/21 – When the hoist is lowered half way we fill in new oil. This helps to cool the engine and, as we know from Type 1, exact valve clearance and timing settings cannot be carried out on a hot engine. If multi-grade oil is not used we must pay attention to the instructions concerning single grade oils which differ on Type 3 and Type 1.

You should make a habit of checking the oil level after each oil change.

Hyp. SAE 90



18/22 – Type 3 has the same roller steering as introduced on Type 1 from August 1961. The lubrication and maintenance instructions for the steering are the same for both models. In Type 3 we must remove the spare wheel well if we want to check the oil level in the steering gear. The oil level should be up to the lower edge of the filler hole. Only Hypoid oil SAE 90 must be used for topping up – the same oil as specified for the transmission.



18/23 – We must always be suspicious if brake fluid losses occur between maintenance services. In such cases we must check the brake system very carefully and examine the lines and connections with the brake pedal depressed.

If the leak cannot be eliminated immediately during the maintenance service we must on no account omit to make an entry in the card "Defects noted during Maintenance".



18/24 – The presence of a fuel pump filter saves the time spent in cleaning the carburetor.

The arrow shows the hose clamp with which we seal off the feed hose before removing the cover. The filter is cleaned with benzine. Hardened gaskets should always be replaced. Make sure that the cover seats properly by moving it slightly to and fro so that the pump does not draw in air.

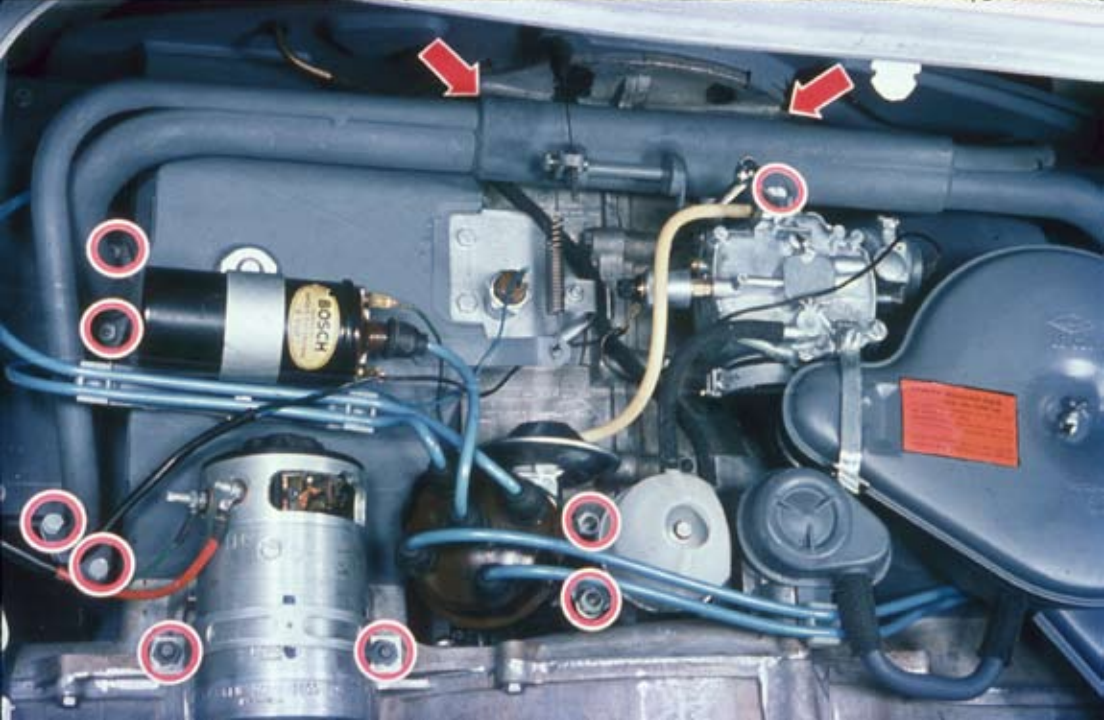

18/25 – This picture shows the connections on the engine which require particular attention during the 300 miles maintenance service.

The connections shown in rings are the nuts and bolts on the intake manifold, pre-heating pipe, fuel pump, carburetor and generator mounting strap. The bolts of the upper engine mounting shown here by the two arrows have to be checked for tightness.



18/26 – In August 1962 the pre-heating pipe was provided with a valve which heats the intake manifold via a bi-metal spring.

During the maintenance service we check the valve throttle for free movement by pulling up the operating lever behind the bimetal spring shown in red against the spring pressure. When released, the lever must return to its original position immediately. If it is stiff, it can usually be freed off by pulling and releasing the lever a few times. If this is not successful, the valve must be removed after the maintenance service has been completed, freed off or replaced.



↓ 0,7 mm
↑ (0.027")

BOSCH



18/27 – Not much time can be spent when cleaning the spark plugs. This operation can be carried out successfully by a sand blaster in a few seconds. Please note, however, that depending on the amount of deposits, the sand blaster should only be operated for about 5 to 10 seconds – on no account for a longer period. If this period is exceeded not only will the deposits be removed but also the electrodes and insulator will be affected.

If necessary the plug gap is re-set to 28 thou.



18/28 – Care should be exercised when lubricated the distributor to ensure that oil or grease is only applied where it is really required.

The breaker base plate felt ring is soaked in oil in the factory. It merely serves the purpose of lubricating the contact breaker plate so that it can move easily. It is sufficient to lubricate the felt ring with a few drops of engine oil every 3,000 miles through the hole illustrated by the arrow.

The small amount of grease on the breaker arm fibre block usually contains abrasive dust.

It is always best to remove the old grease, clean the cam slot with a cloth soaked in petrol and to apply high melting point grease. Multi-purpose grease is also suitable. Normal high pressure grease is not suitable because it is not sufficiently heat resistant.



18/29 – The breaker points should always be washed in benzine during maintenance services. The distributor cap should also be cleaned on the inside and outside and the breaker housing blown out with compressed air. On the other hand, the contacts should not be removed and filed each time.



1



2



18/30 – During the course of operation material is transferred from one contact to the other. If this is only slight the function of the contacts will not be impaired.

Picture 1 shows how a hole has formed on the breaker arm with the corresponding build-up on the fixed contact.

Picture 2 illustrates how then contacts are often adjusted incorrectly in such cases.

If these contacts are measured with a feeler gauge and the build-up is not taken into consideration, the measuring error shown here will occur: The actual contact gap is the height of the build-up plus the thickness of the 16 thou feeler gauge. "a" denotes the incorrect gap. These mistakes can be avoided if we insert the feeler gauge at the edge only.

Oxydized contacts or those with excessive build-up can be removed and cleaned up but in most cases this takes too long. The best and most economical way is to replace the contacts.



18/31 – The crankshaft pulley now has 3 timing marks. The left mark signifies 7.5° the center one 10° and the right-hand one 12.5° before T.D.C. The blue arrow denotes the direction of turning. In general we are only interested in the central mark as most of the 1.5 litre engines are set to 10° T.D.C. The 12.5° marking, only valid for approximately 20,000 vehicles between chassis numbers 65 567 and 84 751 which had a modified carburetor adjustment. We must, however, bear these chassis numbers in mind. If a engine tends to pink when using fuels with insufficient anti-knock properties, the timing can be retarded 2.5° each time.



18/32 – The engine must always be sufficiently cold before the ignition can be checked or set. The oil temperature in the crankcase must not exceed 50 °C (122 °F). When checking and adjusting the ignition timing we use a 6 volt test lamp and the adjustment gauge VW 660 which is mounted on the adjustment surface of the fan housing. The point of the gauge and the center of the timing mark on the crankshaft pulley must be in line. The engine must only be turned in a clockwise direction to take up the play in the distributor drive gear.



18/33 – The valve clearance is also affected by the heat of the engine: the clearance is reduced when the engine becomes warm. This is why the valve clearance should only be checked or set when the engine is cold or fairly warm. As opposed to the 34 bhp engine the clearance is:
for intake and exhaust valves 12 thou at a maximum oil temperature of 50 °C (122 °F). Since a normal 13 mm box wrench is not suitable we use a lengthened socket wrench which consists of a box wrench and a 13 mm socket wrench insert which can be made by every workshop.



18/34 – By checking the compression we gain knowledge on the condition of the engine. In particular we can ascertain whether the compression in one cylinder has fallen. To obtain comparative values with earlier tests it is necessary to check under the same conditions i. e. engine temperature, starting motor revolutions and testing devices should be the same.

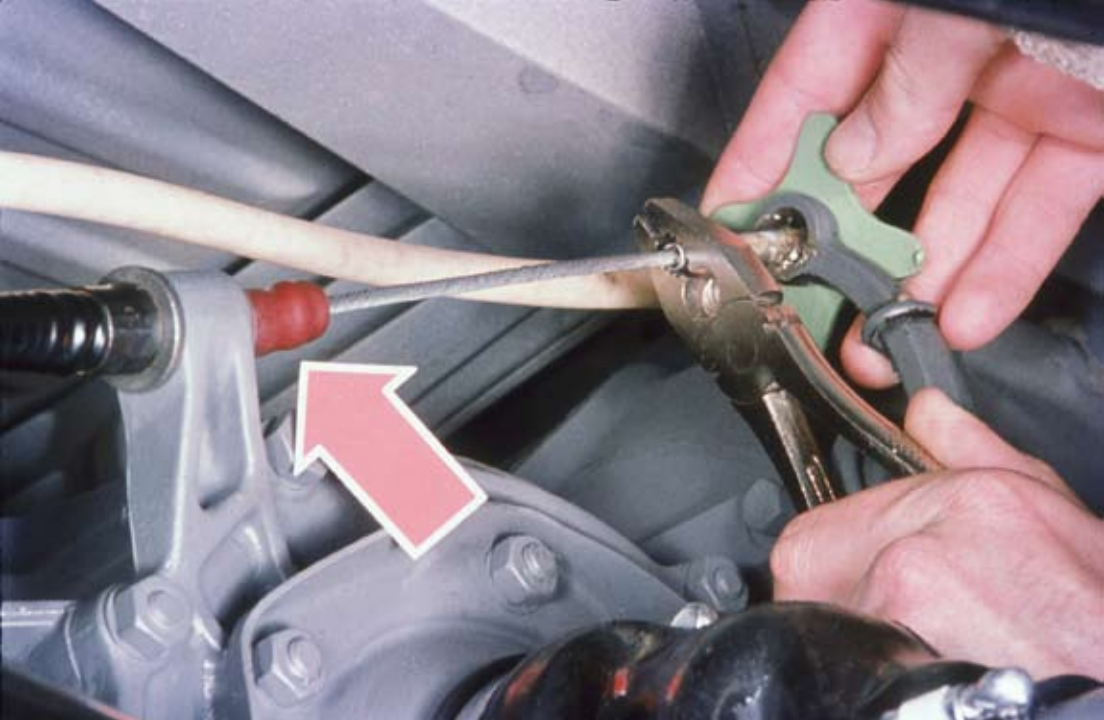

18/35 – The locally manufactured star-shaped adjusting wrench is suitable for all Volkswagen models. This will also facilitate the clutch adjustment operations on Type 3.

If we lubricate the ball socket in the threaded piece generously the adjusting nut in the clutch lever will have sufficient free movement and we can save ourselves the trouble of having to free off the adjusting thread during the next maintenance service. The arrow shows the sealing sleeve at the end of the cable guide. Here too we must make sure that it is properly seated.

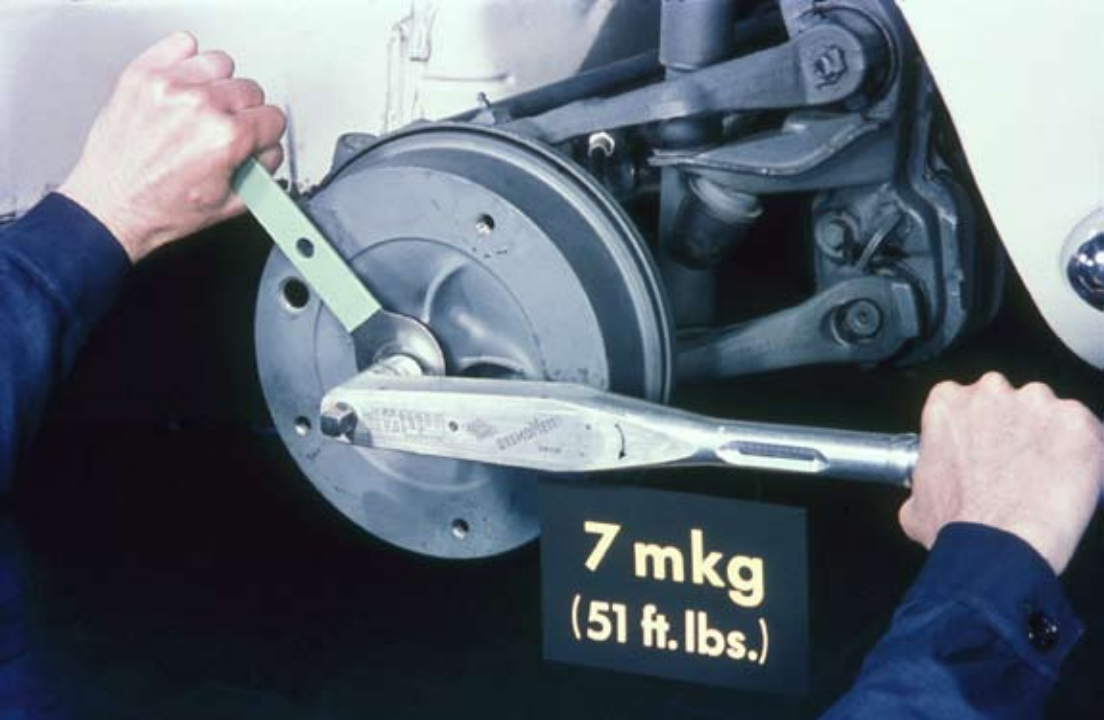

7 mkg
(51 ft. lbs.)

18/36 – The front wheel bearing play is checked at the 300 mile maintenance service. If it is necessary to adjust the bearings we use a torque wrench.

First of all the inner bearing nut is tightened to 21 ft. lbs. This seats the bearings properly. Now slacken the nut until the thrust washer can just be moved with a screwdriver, hold the nut in this position and tighten the lock nut to 50 ft. lbs. Always use a new lock plate. This operation is shown here. The bearings are correctly adjusted if we can just move the thrust washer and the wheels moves freely in both directions without axial play.



18/37 – Before lubricating the front wheel bearings at 30,000 miles with grease as specified in the Maintenance Chart, the bearings and inner hubs are washed out carefully and the bearings checked for wear. The prescribed heat-resistant multi-purpose grease is packed between the cages and the rollers and the space between bearing seats is also filled with grease.

Why is it wrong to fill the complete hub with grease? Only a very thin layer of grease lubricates the roller bearings: superfluous grease must have space to expand into the hub.



18/38 – The pressures of the low section tires on Type 3 must be strictly adhered to so that full advantage can be taken of the excellent driving characteristics of the car. It is absolutely necessary that the tire pressures are correct when checking the camber and toe-in.

Unless stated otherwise by the customer, the correct tire pressures for the Sedan and Coupé for fast motorway driving is 17 lbs./sq. in. at the front and 24 lbs./sq. in. at the back. These values apply also to the two Variant models under half-load conditions. The red arrow points to the location of the tire pressures for the vehicle in question. Only on the Coupé are there pressures shown on the inside of the glove compartment lid.

We have already convinced ourselves – when the car was raised – that the tires are road safe and do not show signs of abnormal wear.



18/39 – If all the auxiliary tools are readily to hand it only takes a few minutes to see to the battery. The acid level should be topped up to the correct mark. A damp oily film on the battery – nearly always a sign of excessive acid – should always be carefully removed. This layer facilitates tracking and causes the battery to discharge. We use a cell tester to check whether the battery is sufficiently charged and that the cells are in order.



18/40 – In Type 3 only the generator is driven by the V-belt. This however does not relieve us of the obligation of checking it for correct tension. When pressed firmly with the thumb it should yield approximately .6". The tension is altered in the usual way by removing or inserting spacer washers.

We also check whether both pulley halves run true and do not foul the housing. The yellow arrow shows the correct distance between V-belt and housing. The clearance should be .16" at least.

The red arrows point to the rubber boot on the housing and the housing cover gasket. Both seals must be undamaged and be correctly seated if the generator is to be cooled efficiently.



18/41 – After cleaning oil bath cleaner it is filled with 0.44 Imp. pints or 0.53 U.S. pints of SAE 20 engine oil.

The red arrow points to the connection between air cleaner and carburetor. We must make sure that the elbow is a proper fit on the air cleaner before we tighten the retainer. The green arrow points to the pre-heater flap. This flap is checked for free movement as well as the seating of the pre-heating control box on the intake duct. The blue arrow illustrates the boot which must be in perfect condition and must seal efficiently.



18/42 – These are official regulations concerning the adjustment and brightness of headlamps. Both headlamps must be equally bright. The arrow points to the light meter which is incorporated in the aiming device. The brightness of the headlamps can be read from this device. If the minimum values are not reached we must make an entry in the card "Defects noted during Maintenance".

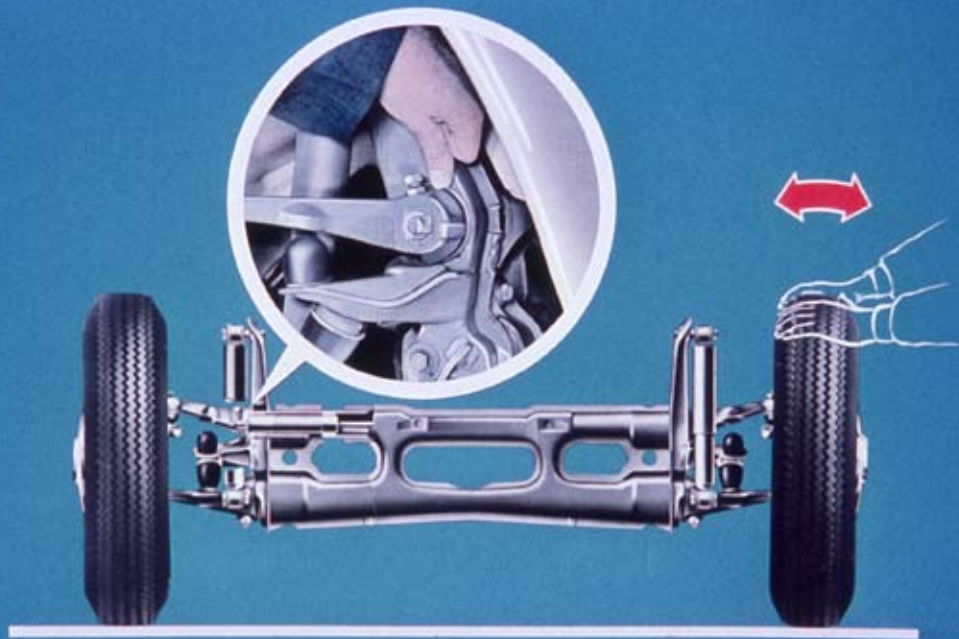

18/43 – The upper torsion arms of the front axle are connected by the stabilizer and must not have any axial play. The play is checked as follows: We bounce the vehicle at the front and rear so that the wheels are no longer in a loaded condition.

Whilst one mechanic rocks the wheel gently we check the gap between anchor plate and torsion arm on the other side – as seen in the circle. If torsion arm movement cannot be detected, the axial play is correct. Do not rock the wheel violently. This will cause the torsion arms to lift in their bushes and give an incorrect impression.



18/44 – If the thrust rings show signs of wear the torsion arms must be adjusted by the adjusting screw situated at the right-hand torsion arm: Loosen the clamping bolt which is secured by a lock nut on the top of the torsion arm and after bending up the lock plate tighten the adjusting screw – shown here with the box wrench in situ. This will center the torsion arms. The adjusting screw is now removed and a new lock plate fitted. We now move the lock plate to and fro in the direction of the red arrows and tighten the adjusting screw until the lock plate can just no longer be moved by hand. This operation is shown in the picture. Now tighten the clamping bolt and secure with the lock nut. We then tighten the

adjusting screw slightly – check the axial play as shown in the previous picture – and secure the screw with the lock plate.



$1^{\circ}20' \pm 20'$

18/45 – The vehicle must be level if the camber and toe-in are to be measured correctly. The vehicle must also be unladen and the front wheels in the straight-ahead position. Two measurements are taken with the protractor VW 261 to avoid incorrect readings. Here you see how we position the protractor on the wheel disc. We mark the location with a piece of chalk and ascertain the camber value. We now push the car back or forward half a wheel turn and take measurements at the same location again. We divide the sum of both readings by two to arrive at the mean value which must not be above or below the specified value of $1^{\circ}20' \pm 20'$.



3-5 mm

0,12-0,20''

18/46 – We then check the toe-in. Adequate readings can be obtained if we use an alignment gauge which is provided with a dial indicator. The toe-in of Type 3 when unladen should be between .12" and .2".



1

2

18/47 – If the camber and toe-in values deviate from the prescribed readings the vehicle will have to be driven to a special measuring bay. This is the only way of ensuring that we can carry out the adjustments under the vehicle with its wheels on the ground as specified. First of all re-set the camber by means of the eccentric pin in the upper ball joint – arrow 1. Only if this adjustment is not sufficient do we effect an adjustment at the lower ball joint (arrow 2).

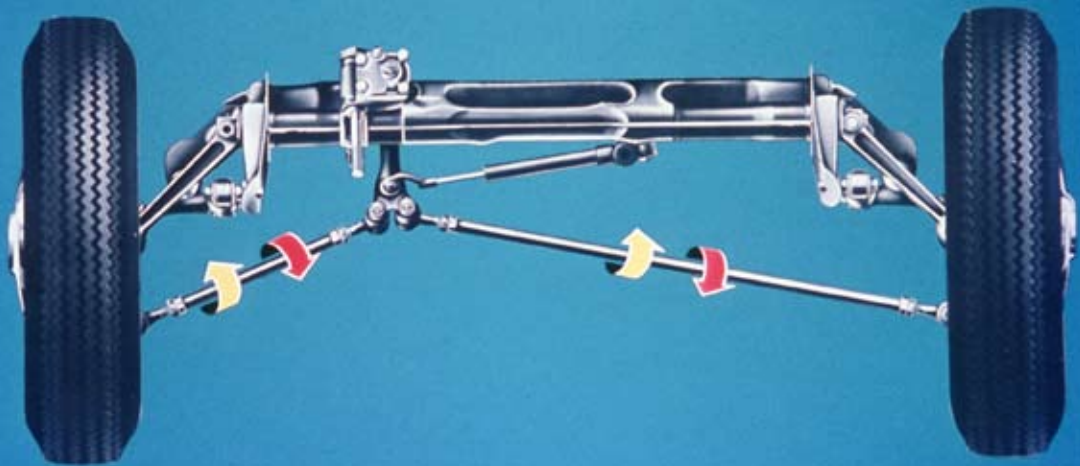

18/48 – The toe-in is adjusted by turning the tie rod tubes. Both tie rods must be lengthened or shortened by the same amount so that the center position of the steering will not be effected. By turning the tie rods in driving direction – yellow arrow – we increase the toe-in, by turning them in the opposite direction – red arrow – we reduce the toe-in. By using an optical wheel alignment gauge exact camber and toe-in settings can be achieved.



18/49 – If a stationary test stand is not available, the vehicle will have to be road-tested after the maintenance service to check the vehicle thoroughly and to see if the adjustments have been carried out satisfactorily.

The use of a brake test stand does away with the necessity of the less reliable brake test and the element of danger. Here we see the car on the roller test stand which makes it possible to get a clear picture of the braking force of each individual wheel at a certain pedal pressure.



18/50 – Always remember that the purpose of the maintenance service is not merely to carry out efficiently the operations listed in the Service Booklet. It is just as important that we discover defects in good time which, if they are not eliminated in good time, can involve heavy expenses later on or can result in breakdowns or even accidents.

Enter in the defects immediately on the card "Defects noted during maintenance". The service adviser must be in a position to give the customer a clear picture of the condition of his car. Only then has the real aim of the maintenance service been achieved.